

# Remote Monitoring System for Mine Safety using Wireless Sensor Network

<sup>1</sup>Mahendran J,  
Assistant Professor,  
Department of Mining Engineering,  
Dr. T Thimmaiah Institute of  
Technology,  
K.G.F, Karnataka-563120,

<sup>2</sup>Srinivas K, <sup>3</sup>Vinith Kumar P V,  
<sup>4</sup>Krishnaraj S, <sup>5</sup>Nagarajayak  
Students

**Abstract:** Today safety of miners is major challenge. Miner's health and life vulnerable to several critical issues, which includes not only the working environment, but also the after effect of it. Mining activities release harmful and toxic gasses in turn exposing the associated workers into the dangers of survival. This puts a lot of pressure on mining industry. To increase the productivity and reduce the cost of mining along with consideration of the safety of workers, an innovative approach is required. Miner's health is in danger mainly because of the toxic gases which are very often released in underground mines. Areas in which these gases are present, are considered as critical regions. A real time monitoring system using wireless sensor network, which includes multiple sensors, is developed. This system monitors surroundings environmental parameters such as temperature, humidity and multiple toxic gases this system also provides an early warning, which will be helpful for all miners present inside the mine to save their life before any casualty occurs. The system uses Zigbee technology to establish wireless sensor network which is suitable for operation in harsh environment.

**Keywords:** Toxic gases, Wireless Sensor Network, Zigbee Technology.

## I. INTRODUCTION

Underground mining operations proves to be a risky venture as far as the safety and health of workers are concerned. These risks are due to different techniques used for extracting different minerals, the deeper the mine, the greater is the risk. These safety issues are of grave concern

especially in case of coal industries. Thus, safety of workers should be of major consideration in any form of mining, whether it is coal or any other minerals.

Underground coal mining involves a higher risk than open pit mining due to the problem of ventilation and potential for collapse. However, the utilization of heavy machinery and the methods performed during excavations result into safety risks in all types of mining. Modern mines often implement several safety procedures, education and training for workers, health and safety standards, which lead to substantial changes and improvements and safety level both in opencast and underground mining.

Coal has always been the primary resource of energy in INDIA, Which has significantly contributed to the rapid industrial development of the country. About 70% of the power generation is dependent on it thus, the importance of coal in energy sector is indispensable. But the production brings with it the other byproducts, which proves to be a potential threat to the environment and the

people associated with it. In lieu of that the present work is a sincere attempt in analyzing the graveness and designing a real time monitoring system of detection by using the ZigBee technology.

When underground mining advances continuously, no wired network can be established in real time, naturally, it is thus

impossible to monitor these dangerous regions in real time. In addition, due to cost and maintenance limitations, no safety monitoring systems are installed in abandoned underground tunnels, creating a great potential safety hazard. System integration and mechatronics automation are rapidly moving towards remote monitoring via the internet, which reduces the human resources required to monitoring mechanical functions in factories. With the rapid development of global information technology, an increase in the number of computer users, the maturation of industrial communications technology and improvement in technologies associated with the monitoring system and smart electronic devices, many companies now offer monitoring system with wide range of functions.

Advantech web Access is the first software program based on the human machine interface (HMI) With supervisory control and data acquisition (SCADA) incorporated into browsers saygin and kahraman presented a web-based PLC (programmable logic controller) laboratory for manufacturing engineering. Mougharbel et al. evaluated and compared various remote access laboratory installations around the world.

Hui et al. have suggested that instructors should consider the target knowledge when considering technology assisted learning alternative options designing a web-based course.

The wide spread use of the internet increase the need for web-based applications for distributing searching and exchanging information to and

support various activities the ability to connect to the internet processes an industrial automation, such that the physical boundaries are extended. Web access offers a number of advantages for remote monitoring systems over

conventional structures, such as eliminating need for an additional server system. In this

manner, WebAccess saves time when establishing a system, making it possible to immediately conduct monitoring tests over the internet. Monitoring accuracy requires a visual monitoring system equipped with cameras capable of transmitting images instantaneously and Web-Cam provides an ideal solution.

The laboratory allows users to operate experiments while collecting physical data from a remote location, which are displayed on a screen via a network connections.

Web-based learning technologies can also be applied to general remote control systems in many research and engineering areas. An increasing number of human interface systems are being implemented at all levels of education to support teachers.

In addition to promoting instructional flexibility and permitting the incorporation of new educational resources, web-based learning familiarizes student with computers as a learning tool web-based learning modules used in manufacturing and robotics modules and a senior design project, are presented by Radharamanan and Jenkins engineering educations requires substantial laboratory work that's often costly and rapidly becomes obsolete. There for laboratory experiments have major economic implications for Engineering education.

Through the use of mechatronics module, this study uses internet connectivity using a web server to manipulate various databases. Increasing the number of engineering and monitoring locations connecting to the internet would enable the integration of peripheral resources to gradually expand the structure of remote systems. Remote systems developed in

previous studies require additional web servers that are difficult to maintain and lack direct access to core data because remote monitoring system are additional web pages. By contrast,

the architecture proposed in this work is web-based and all required functions can be realized directly on the web. Web-based learning systems can serve as incentives for university faculties to teach distance education courses. Gadzhanov and Nafalski reviewed the pedagogical effectiveness of distance education, with a special focus on remote laboratories for measurement and control. Machotka et al. proposed the remote laboratory NetLab at the University of South Australia.

NetLab was first developed as learning environment developed as a learning environment that enables students cooperate while conducting remote experiments, domestic and international, via the internet. Herrera and Fuller presented a model for the implementation of the remote experimentation laboratories in a distributed collaborative scenario, focusing on two crucial key elements: shared knowledge and interaction for collaboration. Yang et al. Developed a computer based online learning module to help engineering undergraduates comprehend difficult concepts.

## II. LITERATURE REVIEW

In underground mining, ventilation system are crucial to supply sufficient oxygen, maintaining non-explosive and non-toxic atmosphere and operating an efficient mine. Mine ventilation system can help in eliminating high risk atmosphere. When the atmosphere becomes toxic. Integrating ventilation monitoring system enables mine to intelligently make ventilation changes based on the extensive data, the monitoring system provides. Unexpected changes in the ventilation system are noticed by the monitoring arrangement, allowing prompt action to be considered. New and developing communication and tracking system can be utilized to monitor mines more efficiently and relay the data to the surface.

### *Previous work*

These are the previous research work on different systems using different technologies for mine safety.

- **Tan et al. (2007)** designed a system, which is applied for mine safety monitoring. They called the system WSN based mine safety system. This is capable of remote monitoring of the mine environment and provide the pre-warning for the fire or explosion.

- **NiuXiaoguang et al.(2007)** presented a distributed heterogeneous hierarchal mine safety monitoring prototype system (HHMSM) which is based on futures of the underground mine gallery and necessities of mine safety. This system monitors the methane, concentration and location of miner. The proposed an over hearing based adoptive data collecting system, which makes use of the redundancy and the co relation of the sampling readings in both time and space to age the traffic and control.

- **Hehngjiang et al.(2008)** designed a system using low power ARM (ADVANCED RISC MACHINES) processor chip S3C2410 as the control of core and Zigbee as a communication platform of WSN. This system composed of network mode, communication network of CAN BUS as well as monitoring sensors.

- **Zheng sun et al. (2008)** analysed the problems of mine safety monitoring and an improved TinyOS Beaconing based WSN. This protocol cannot only aware energy and repair route automatically but also can prevent the number of child nodes and that system levels. The futures are small routing table, high stabilization, high self-repairing and long life time. It may be suitable for coal mine data acquisition and applied to mine safety monitoring.

- **Lin-Song Weng et al. (2009)** planned a frame work, which is viably observing all circumstances in mine, particularly for the wellbeing of mine workers. They named the system the real time mine auxiliary monitoring system (RMAMS). Which is embraced for real time mine monitoring system. Mine auxiliary sensor system (MASS) consists of an intelligent activity sensor and repeater and arise at decision to resolve the procedure of processing.

- **Shi wei et al.(2009)** designed a multi parameter monitoring system for coal mine tunnel, which is based on WSN network. This system uses the RS-485 communication protocol and hardware modular. It automatically sends warning signals to the main control room and accomplishes corresponding control.
- **Wenge li et al.(2009)** designed a system for remote monitoring and analysis of mines using virtual instrument technology, network and data base technology. This organization consists of sensor, remote clients, the ground monitoring center and the underground substation. The remote clients, through internet explorer, can browse the remote monitoring data of mine safety such as temperature, gasoline, wind velocity, carbon monoxide and so on. The system stored the data using ADO in Labview.
- **Hongmeiwu et al.(2010)** proposed a remote monitoring system for the vehicle based on wireless sensor technology. This scheme uses the sensor nodes, deployed on the vehicles to collect speed, pressure, oil level value, and data to the ARM based information processing terminal.
- **Li-Chien Huang et al. (2011)** designed a system for building electrical safety. No fuse breakers (NFBs) and electrical wall plugs are the main components of traditional distribution, which is used for power transmission and over load protection. NFBs have the utilization of overburden security and are not completely compelling in forestalling electrical flames created by poor contact are dust pollution. This plan built with assurance instruments so as to upgrade the parts of customary a circulation frame works. The effects and other equipment's in the same branch circuit can be awaited threshold limit of the system when the outlet disconnects the power.
- **Ge bin et al, (2011)** suggested a method for monitoring coal mine using Zigbee technology. This system measures the various safety factor of production such as gas, temperature, humidity and other environmental indicators.
- **Cheng Bo et al, (2012)** proposed a restful web services improved coal mine safety monitoring

and control automation using WSN network. This system can collect the values of methane, temperature, humidity and personal position information inside the mine.

- **RajkumarBoddu et al,(2012)** designed a coal mine monitoring system using Zigbee based on GSM technology. The degree of monitoring safety can be improved using this scheme and reduce misfortune in the coal mine. They purposed a solution suitable for mine wireless communication, and safety monitoring using this scheme.

- **Hongmeiwu et al, (2010)** proposed a remote monitoring system for the vehicle based on wireless sensor technology. This scheme uses the sensor nodes, deployed on the vehicles to collect speed, pressure, oil level value, and data to the ARM based information processing terminal.

- **Ge bin et al, (2011)** suggested a method for monitoring coal mine using Zigbee technology. This system measures the various safety factor of production such as gas, temperature, humidity and other environmental indicators.

- **Cheng Bo et al, (2012)** proposed a restful web services improved coal mine safety monitoring and control automation using WSN network. This system can collect the values of methane, temperature, humidity and personal position information inside the mine.

- **RajkumarBoddu et al,(2012)** designed a coal mine monitoring system using Zigbee based on GSM technology. The degree of monitoring safety can be improved using this scheme and reduce misfortune in the coal mine. They purposed a solution suitable for mine wireless communication, and safety monitoring using this scheme.

### III. OBJECTIVE

- A remote monitoring system may assist in monitoring and control over the mining environment. Zigbee technology offers its most of the advantages ideal for the remote monitoring system. Thus, the primary objective

of this project is decided to design an efficient remote monitoring system so that various leaked mine gases could be identified at times and preventive measures could be devised accordingly.

▪ The research investigations to be carried out with the following objectives:

1. Detection of different toxic gases within mining environment
2. Communication establishment between sensors and Zigbee
3. Establishment of wireless sensor network
4. Design of a remote monitoring system

#### IV. PROBLEM STATEMENT

▪ The problem: How to prevent (or reduce impact of) unsafe incidents in underground mines, specifically coal mines.

- Prevent fire / explosion accidents
- Prevent unsafe incidents impacting health

#### V. METHODOLOGY

▪ We need to assist a remote monitoring of gasses and fire explosion in real time, we need a monitoring system to monitor the fire accidents and harmful gasses, and need to monitor the temperature, humidity, methane, carbon monoxide so monitor these parameters, need some sensors that sensors have used is DHT22 sensor, humidity sensor, MQ4 and MQ7 sensors are used.

▪ After getting values from sensors we need to send the information to computer, so some can monitor the parameters and also parameter exceeds the threshold value, we need a buzzer basically to give an alarm that exceeds the threshold value.

▪ We give two units one is sensor unit and another one is monitoring unit, sensor unit has sensors like DHT22 sensors, humidity sensors, MQ4 and MQ7 sensors are connected to the microcontroller and microcontroller basically accepting sensors data and control the buzzer LED and Zigbee transmits the data to the Zigbee receiver, so I am actually using Zigbee technology because this range is very high

250kbps, Zigbee is suitable for sensors technology.

▪ I have used two Zigbee, one Zigbee has transmitter another Zigbee has receiver, so this Zigbee transmitter basically connects from microcontroller and transmits the Zigbee receiver that is in the monitoring unit, and Zigbee receiver collects the data from Zigbee transmitter.

#### VI. SYSTEM DESIGN

This consists of the design of the system. This mainly contains the details of required hardware and software. The appropriate working environment is setup with all required components to develop the system. After developing the system, it is tested in the particular environment. This explains the step-by-step development of hardware system followed by software development and its implementation.

##### *System hardware design*

This monitoring system contains several components like boards (ATmega2560, Zigbee module and USB interfacing board), LCD (liquid crystal display), different sensors and other small electronic components. This chapter gives a detailed review of each of the parts along with its working principle.

##### *Arduino mega*

The Arduino Mega is a microcontroller board based on the ATmega2560. It has 54 digital input/output pins (of which 14 can be used as PWM outputs), 16 Analog inputs, 4 UARTs (hardware serial ports), a 16 MHz crystal oscillator, a USB connection, a power jack, an ICSP header, and a reset button. It contains everything needed to support the microcontroller; simply connect it to a computer with a USB cable or power it with an AC-to-DC adapter or battery to get started. The Mega is compatible with most shields designed for the Arduino Duemilanove or Diecimila.

The Mega 2560 R3 also adds SDA and SCL pins next to the AREF. In addition, there are two new pins placed near the RESET pin. One

is the IOREF that allow the shields to adapt to the voltage provided from the board. The other is a not connected and is reserved for future purposes. The Mega 2560 R3 works with all existing shields but can adapt to new shields which use these additional pins.

**PROJECT REQUERMENTS**  
**Arduino mega**

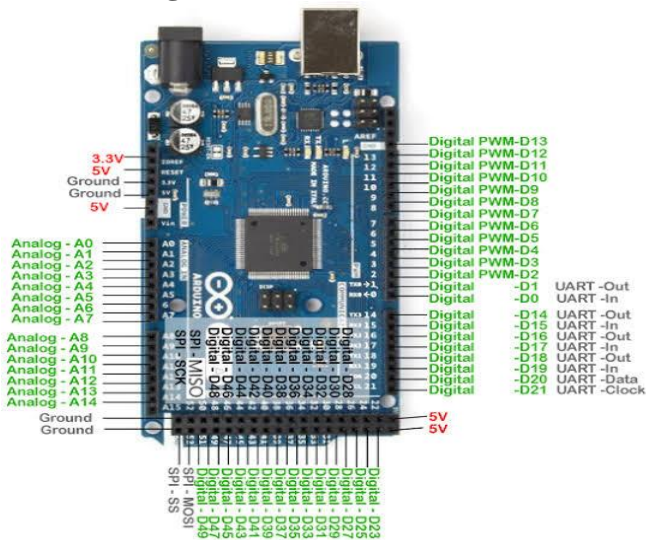

Fig3.1

**Table 3.1: Technical Specification of Microcontroller**

Microcontroller	AT Mega 2560
Operating Voltage	5v
Input Voltage (recommended)	7-12v
Input Voltage (limit)	6-20v
Digital I/O Pins	54(of which 15 provide PWM output)
Analog Inputs Pins	16
CPU	8-bit 8051family
Flash Memory	256 KB of which 8 KB used by boot loader
SRAM	8KB
Clock Speed	16 MHz

**DHT22-TEMPARATURE AND HUMIDITY**

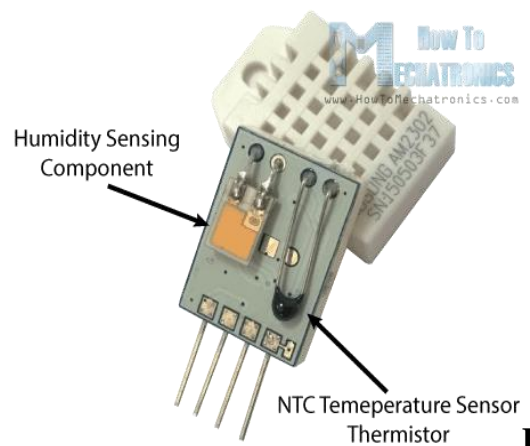
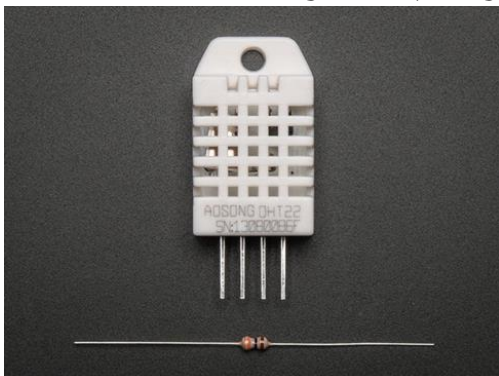

Fig 3.2

The DHT22 is the more expensive version which obviously has better specifications. Its temperature measuring range is from -40 to +125 degrees Celsius with +-0.5 degrees accuracy, while the DHT11 temperature range is from 0 to 50 degrees Celsius with +-2 degrees accuracy. Also the DHT22 sensor has better humidity measuring range, from 0 to 100% with 2-5% accuracy, while the DHT11 humidity range is from 20 to 80% with 5% accuracy.

**MQ4 SENSOR (METHANE)**

**MQ-4**



Fig 3.3

MQ-4 gas sensor composed of ceramic tube and tin dioxide. Electrode and heater are fixed into a layer. The heater provides required work conditions for the work of sensitive components.

When the target combustible gas present, the conductivity of sensor is higher along with the gas concentration rising. The MQ-4 sensor has 6 pins in which 4 of them are used to fetch signals

and other 2 are used for providing heating current.

Parts	materials
1. Gas sensing layer	sno2
2. Clamp ring	copper plating Ni
3. Heater coil	Ni-Cr alloy
4. Electrode	Au
5. Tubular ceramic	Al2O3
6. Anti –explosion stainless steel gauze	Network
7. Electrode line	Pt

Table 3.2

MQ-7 SENSOR (CO)



Fig 3.4

MQ-7 semiconductor sensor is mainly used for detecting carbon monoxide(c0).

MQ-7 gas sensor composed of micro Al2O3 ceramic tube and Tin Dioxide(sno2). Electrode and heater and fixed into a crust. The heater provides required work conditions for the work of sensitive components.

The conductivity of sensor is higher along with the gas concentration rising. When the sensor, heated by 5v it reaches at high temperature, it cleans the other gases absorbed under low temperature. The MQ-7 have 6 pins in which 4 of them are used to fetch signals and other 2 are used for providing heating current.

Parts	materials
1. Gas sensing layer	SnO2
2. Rein base	Bakelite
3. Electrode line	Pt.
4. Tube pin	Copper plating Ni
5. Tubular ceramic	Al2O3
6. Electrode	Au
7. Clamp ring	Copper plating Ni
8. Heater coil	Ni-Cr alloy
9. Anti – explosion stainless steel gauze	Network stainless steel gauze

TECHNICAL SPECIFICATION OF MQ7

Model No.		MQ-7	
Sensor type		Semiconductor	
Standard Encapsulation		Plastic	
Detection Gas		Carbone Monoxide	
Concentration		10-10000ppm CO	
Circuit	Loop Voltage	$v_c$	$\leq 10V$ DC
	Heater Voltage	$V_H$	5.0V $\pm$ 0.2V AC or DC (High) 1.5V $\pm$ 0.1V AC or DC (Low)
	Heater Time	$T_L$	60 $\pm$ 1S (High) 90 $\pm$ 1S (Low)
Character	Heater Resistance	$R_H$	31 $\Omega$ $\pm$ 3 $\Omega$ (Room Temp)
	Heater Consumption	$P_H$	$\leq 350mW$
	Sensing Resistance	$R_S$	2K $\Omega$ -20K $\Omega$ (in 100ppm CO)
	Sensitivity	S	$R_S(\text{in air})/R_S(100ppm CO) \geq 5$
	Slope	$\alpha$	$\leq 0.6(R_{500ppm}/R_{100ppm CO})$
Condition	Temp. Humidity	20 deg Celsius $\pm$ 2 deg Celsius: 65% $\pm$ 5%RH	
	Standard Test Circuit	$V_C$ : 5.0V $\pm$ 0.1V: $V_H$ (High) : 5.0V $\pm$ 0.1V: $V_H$ (Low) : 1.5V $\pm$ 0.1V	
	Preheat	Over 48 hours	

Table 3.3

16X2 LCD

A Liquid Crystal Display (LCD) is a low cost, low-power device capable of displaying text and images. LCDs are extremely common in embedded systems, since such systems often do not have video monitors like those that come standard with desktop systems. It can be found in numerous common devices like watches, fax and copy, machines and calculators.

**Pin configuration of LCD**



**FIG3.5**

**LCD pin descriptions:**

**VDD (Pin2), VSS(Pin1):**

VDD and VSS provide +5v and ground, respectively.

**VO (Pin3):**

VO is used for controlling LCD contrast.

**3. Piezoelectric Buzzer:**

A piezoelectric element may be driven by an oscillating electronic circuit or other audio signal source, driven with a piezoelectric audio amplifier. Sounds commonly used to indicate that a button has been pressed are a click, a ring or a beep.



**Fig3.6**

The **piezo buzzer** produces sound based on reverse of the piezoelectric effect. The generation of pressure variation or strain by the application of electric potential across a piezoelectric material is the underlying principle. These buzzers can be used alert a user of an event corresponding to a switching action,

counter signal or sensor input. They are also used in alarm circuits.

The buzzer produces a same noisy sound irrespective of the voltage variation applied to it. It consists of piezo crystals between two conductors. When a potential is applied across these crystals, they push on one conductor and pull on the other. This, push and pull action, results in a sound wave. Most buzzers produce sound in the range of 2 to 4 kHz.

The Red lead is connected to the Input and the Black lead is connected to Ground.

**3.1 FLOW CHART OF THE MONITORING SYSTEM FOR SENSOR UNIT**

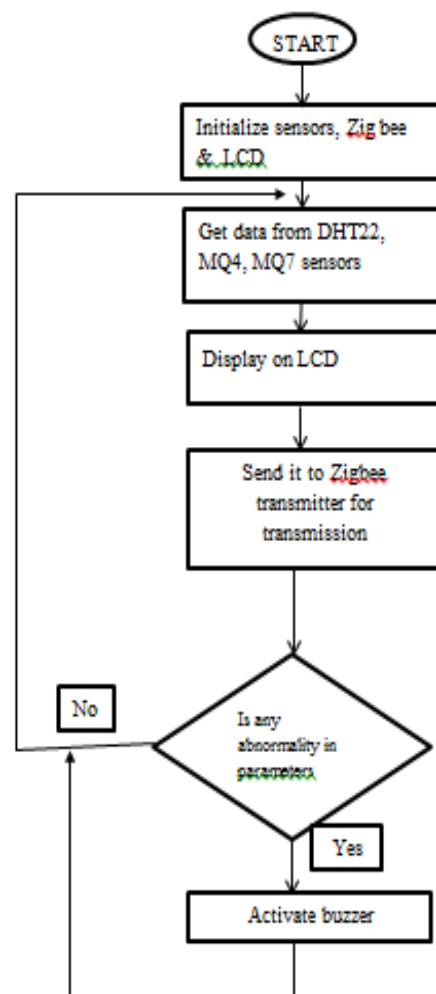

**Fig 3.7**



**3.2 BLOCK DIAGRAM OF THE MODEL ZIGBEE TRANSMITTER UNIT**

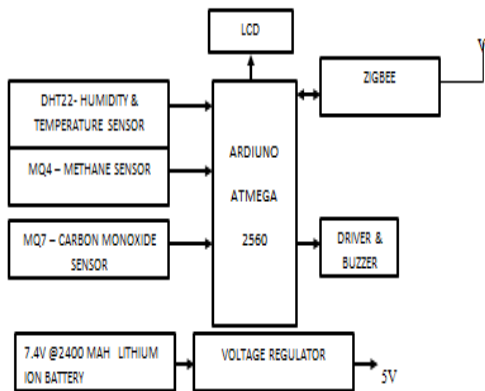

**ZIGBEE RECEIVER UNIT**

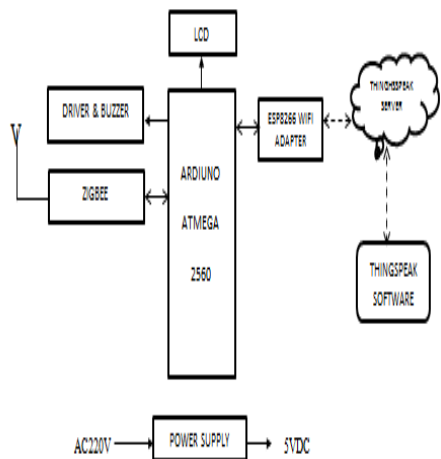

**Fig 3.8**

**BLYNK**

Blynk is designed for the Internet of Things. It can control hardware remotely, it can display sensor data, it can store data, visualize it and do many other cool things.

There are three major components in the platform:

- **Blynk App** - allows to you create amazing interfaces for your projects using various widgets we provide.
- **Blynk Server** - responsible for all the communications between the smartphone and hardware. You can use our Blynk Cloud or run your private Blynk server locally. It's open-source, could easily handle thousands of devices and can even be launched on a Raspberry Pi.

➤ **Blynk Libraries** - for all the popular hardware platforms - enable communication with the server and process all the incoming and outgoing commands.

Now imagine: every time you press a Button in the Blynk app, the message travels to the Blynk Cloud, where it magically finds its way to your hardware. It works the same in the opposite direction and everything happens in a blink of an eye.

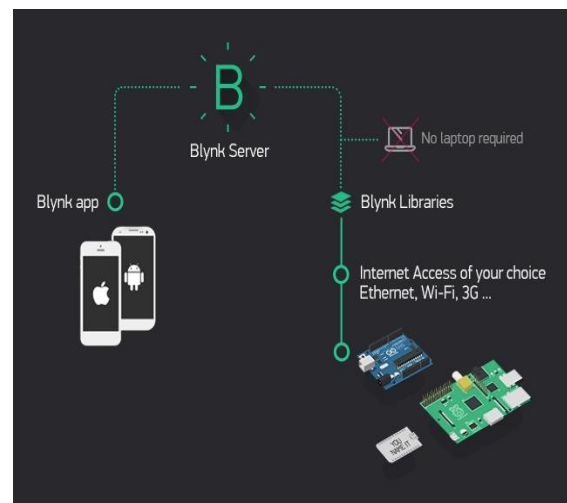

**VII. IMPLEMENTATION**

As of now we have been implementing the underground unit which comprises of MQ4 methane sensor, MQ7 carbon-monoxide sensor, DHT22 digital humidity & temperature sensor , 16\*2 alphanumeric LCD, NRF24LO1+Zigbee transceiver, DC to DC buck convertor and lithium ion battery pack.

- MQ4 methane sensor is tested using methane present in the MINE model.
- MQ7 carbon-monoxide sensor is tested using the carbon monoxide gas present in mine model.
- DHT22 digital humidity & temperature sensor Is tested by placing the sensor in different hot and cold environments.

A device which is used for REMOTE MONITORING SYSTEM FOR MINE SAFETY USING WIRELESS SENSOR

NETWORK in underground mines and display continuous LCD values in analytical format,

➤ The device which we made, it consists of 2 units, one is underground unit and another one is central unit.

➤ The complete model is implemented to check its working liability on the underground of the mine model, where mine gases are present.

The implementing procedure followed as:

➤ Preparations are made at suitable locations of mine for implementing the model.

➤ As our device consists of 2 parts, we are fixing 1 part in underground level that mainly called underground unit, it will place where mine gases are present in mine, 2nd part is central unit that is placed on the above surface.

➤ Now operating the device, the data collected at each parameter is transferred to the central system regularly at real time through zigbee transceiver and the values is also displayed on LCD of the respective parameter.

➤ The data on the central system is also monitored in our smart phone by connecting it to the central system through wifi.

➤ Blynk app is used in the smart phones to monitor the data, where the data is displayed at real time analytically at any point of time.



CENTRAL UNIT

### VIII. RESULT

▪ The study on remote monitoring of toxic gases and other parameters present in underground mine has analyzed using wireless sensor network. A remote monitoring system is developed to provide clearer and more point to point perspective of the under ground mine. This system is displaying the parameters on the LCD at the underground section where sensor unit is installed as well as on the monitoring unit , it will be helpful to all miners present inside the mine to save their life before any casually occurs. Alarm triggers when sensor values crosses the threshold level. This system also stores all the data in the computer for future inspection.

From the experiments and observations, the following conclusion can be drawn:

- 1) Each node in a particular framework functions as the pioneer robot when all its parameters are configured properly.
- 2) Sensors nodes can reconfigure remotely over a wireless network and most of the processing done in software on computer side.

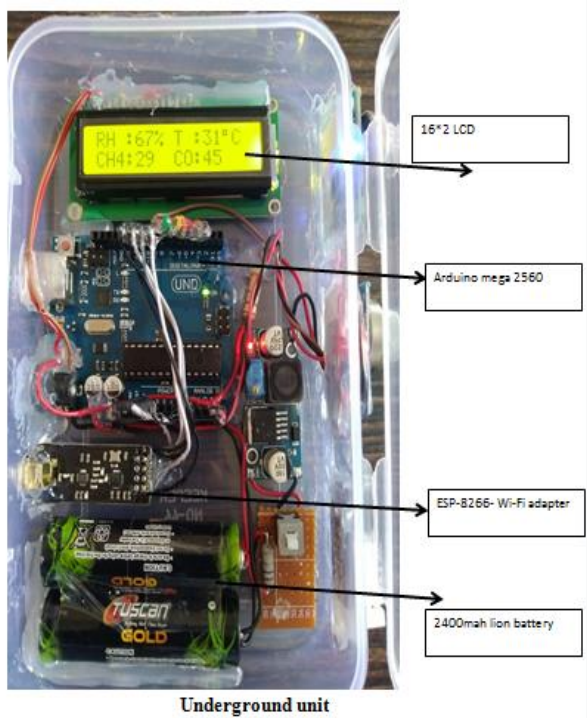

Underground unit

3) The calibration equations of gas sensors may have affected the accuracy of the ppm results.

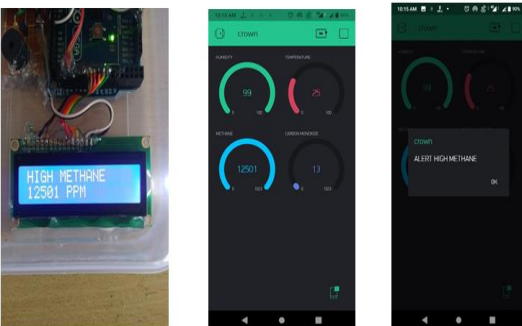
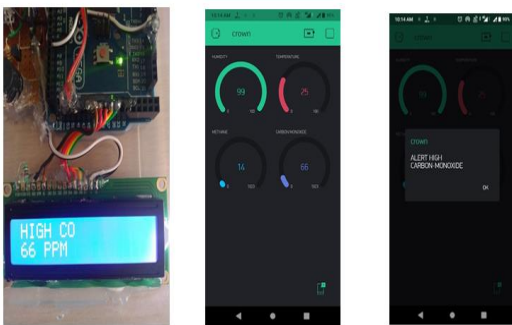
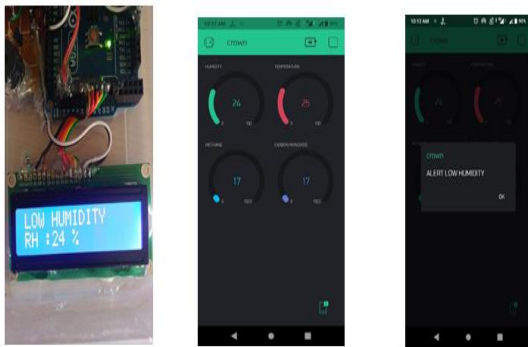
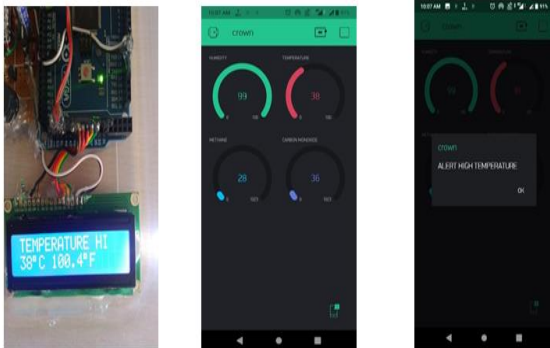

### IX. CONCLUSION

Therefore a complete mine safety system was constructed such that the system is compact and modular, using a combination of mechanical hardware, electronic hardware and specific software. This system can measure ambient characteristics inside the mine environment and communicate them between two nodes using Zigbee communication protocol. The temperature, humidity, methane and carbon monoxide sensor measurements have an accuracy of 89.01%, 98.50%, 90.5%, 89.53% respectively.

### REFERENCES

- [1]. Bin, G., Huizong, L. (2011), "the research on zigbee based mine safety monitoring system".
- [2]. Bo, C., Xiuqan, Q., budan, w., xiaokum, w.et al.(2012), "restful web service mashup based coal mine safety monitoring and control automation with wireless sensor network".
- [3]. Boddu, R., balanagu, p., babu, N.S (2012), "zigbee based mine safety monitoring system with GSM",
- [4]. Boakar, C., "development of wireles sensor network system for indoor air quality monitoring"
- [5]. Dainge, K.M., patil, R.T.(2013), "design of monitoring system for coal mine safety based on MSP430".
- [6]. Hongjiang, L.C., chang, H.C., chen, C.C., kuo, C.C.(2011), "a zigbee based monitoring and protection system for building electrical safety".
- [7]. Kumarsagar, dange, M., patil, R.T.(2013), "design of monitoring system for coal mine safety based on MSP430".
- [8]. <https://www.sparkfun.com/datasheets/sensors/biometric/MQ-7.pdf>  
<https://www.sparkfun.com/datasheets/sensors/biometric/MQ-4.pdf>